

# • SPECIFICATION •

## • 2645SS - STAINLESS STEEL SINK

- FULLY INSULATED (BOTTOM AND SIDES)
- DIAMOND V SHAPED BASE FOR DRAINAGE
- SUPPLIED WITH WASTE KIT
- SUPPLIED WITH OVERFLOW KIT
- SUPPLIED WITH SCREW FIXING KIT FOR UNDERMOUNT INSTALLATION
- 0MM VERTICAL SINK WALL EDGE RADIUS
- 9MM SINK BASE RADIUS FOR EASY CLEANING
- 40MM (EXTERNAL DIAMETER) NOMINAL PLASTIC WASTE PIPE SIZE

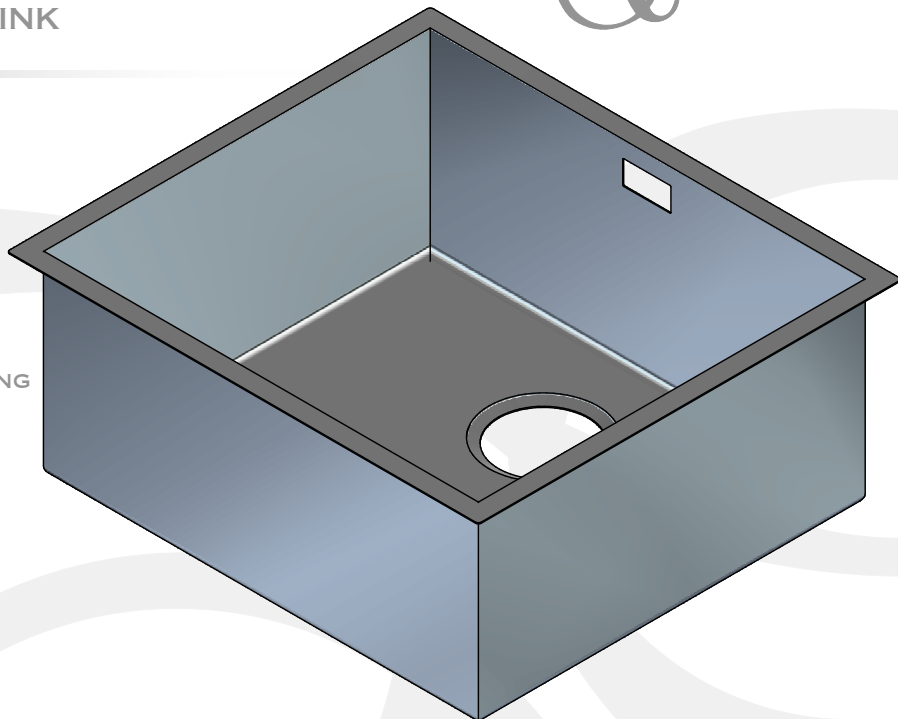

ALL UNITS IN mm  
UNLESS OTHERWISE  
STATED

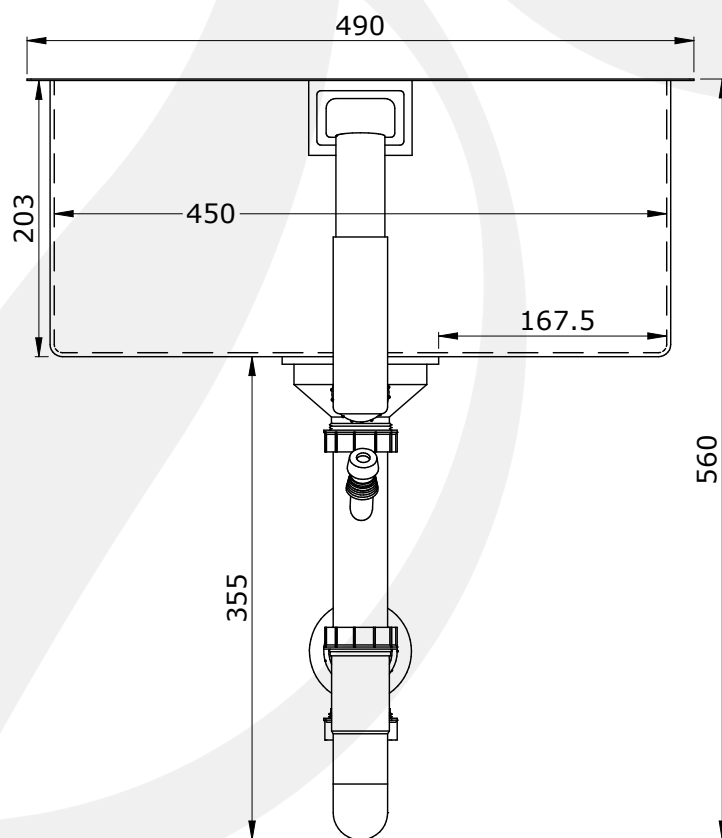
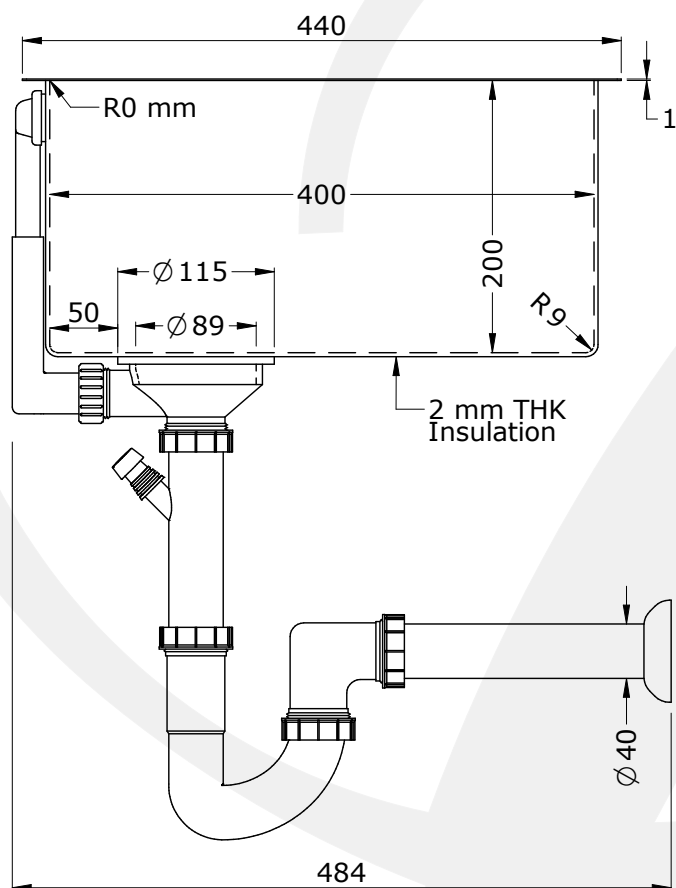

• PACKED WEIGHT: 8.8KG